



Owner's Guide & Installation Instructions

Electromagnetic MultiLog Sensor

Smart™ Sensor

Model **DX900+**

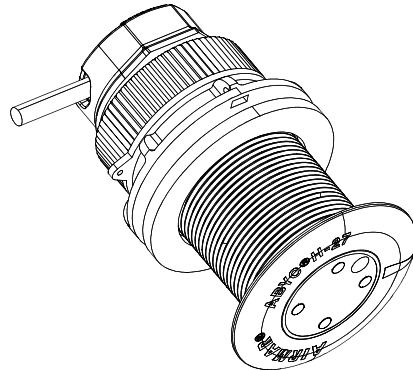
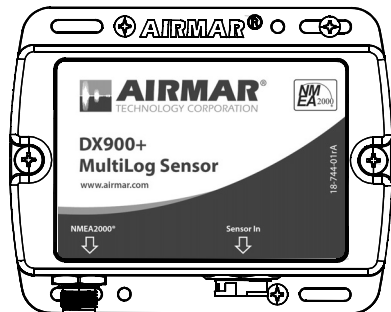

Record the information found on the cable tag for future reference.

Part No. _____ Date _____ Frequency _____

17-626-01-rev.03

03/22/18

Copyright © 2017 - 2018 Airmar Technology Corp. All rights reserved.

All Rights Reserved. Except as expressly provided herein, no part of this manual may be reproduced, copied, transmitted, disseminated, downloaded, or stored in any storage medium, for any purpose without prior written consent of Airmar. Airmar hereby grants permission to download a single copy of this manual and of any revision of this manual onto a hard drive or other electronic storage medium to be viewed and to print one copy of this manual or any revision hereto, provided that such electronic or printed copy of this manual or revision must contain the complete text of this copyright notice and provided further that any unauthorized commercial distribution of this manual or any revision hereto is strictly prohibited.

Information in this manual is subject to change without notice. Airmar reserves the right to change or improve its products and to make changes in the content without obligation to notify any person or organization of such changes. Visit the Airmar website at www.airmar.com for current updates and supplemental information concerning the use and operation of this and other Airmar products.

Table of Contents

Introduction.....	4
Functions & Outputs.....	4
Features & Options.....	4
About the CAST™ App.....	5
Applications.....	6
Tools & Materials.....	6
Warnings.....	7
Choosing the Mounting Location.....	9
Anti-fouling Paint.....	11
Installation.....	12
Installation in a Cored Fiberglass Hull.....	17
Cable Routing & Connecting.....	18
Speed & Temperature Only: NMEA 0183.....	18
Depth, Speed & Temperature: NMEA 2000® or NMEA 0183.....	18
Installing the Processor.....	19
Checking for Leaks.....	21
Operation, Maintenance, & Replacement.....	21
Troubleshooting.....	24

Introduction

Thank you for purchasing Airmar's Electromagnetic MultiLog Sensor. The DX900+ is the industry's first Bluetooth®-enabled, multi-functional unit. It is actually several sensors in a single housing. And it is the only sensor that truly measures leeway instantaneously—not derived from a calculation. Data is output in NMEA 0183 or NMEA 2000® format.

Functions & Outputs	DX900+
Speed	✓
Leeway	✓
Reverse speed	✓
Temperature of water	✓
Depth of water	Optional
Heel & Trim	Optional
NMEA 0183: RS422	Optional
NMEA 2000: CAN	Optional

Features & Options

- Bluetooth®-enabled to connect your boat display and smart devices
- Supports both iOS and Android platforms
- Performs speed calibration and more through the CAST™ app
- Configurable data update rate: up to 10Hz
- Diagnostic information for troubleshooting
- Interface to update firmware
- Dual-axis, electromagnetic, speed sensor
- Fast-response water temperature
- Depth transducer
- Three-axis accelerometer
- Three-axis rate gyroscope
- Retrofits most existing 51 mm (2") thru-hull housings

About the CAST™ App

Download the CAST app by Airmar to view, analyze, and share sensor data and evaluate your sailing performance. Simply install the CAST app on your iOS or Android device to view available NMEA data over a Bluetooth® or network connection. Create custom gauges and page views to see only the data that is important to you. With the CAST app you can perform speed, temperature, and attitude calibrations without extra converters or cables. In addition to firmware updates, the app logs all of the NMEA sensor data over a customized time period for analysis. Smart devices with Bluetooth connectivity can be used to view the data, creating a mobile powerhouse.

Downloading the CAST App

CAST is compatible with Bluetooth® LE-enabled iOS devices.

1. Go to the App Store.
2. Search on the word Airmar.
3. Download the free CAST app (Figure 1).



Applications

- High-speed racing sailboats
- Not recommended for boats designed to pull air under the hull.
- **Plastic** housing recommended for fiberglass or metal hull only.
Never install a plastic housing in a wood hull, since swelling of the wood can possibly fracture the plastic.
- **Stainless steel** housing compatible with all hull materials.
Recommended for aluminum hulls to prevent electrolytic corrosion *provided the stainless steel housing is isolated from the metal hull.*
- Accommodates a deadrise angle up to 22°.
- Depth function has best performance on a hull deadrise angle through 7°.

Tools & Materials

Safety glasses

Dust mask

Ear protection

Water-based anti-fouling paint (**mandatory in salt water**)

Electric drill with 10 mm (3/8") *or* larger chuck capacity

Drill bit: 3mm *or* 1/8"

Hole saw:

Plastic/metal housing in non-metal hull 51 mm *or* 2"

Stainless steel housing in metal hull 57mm *or* 2-1/4"

Sandpaper

Mild household detergent *or* weak solvent (such as alcohol)

File (installation in a metal hull)

Marine sealant (suitable for below waterline)

Measuring tape

Chalk line

Slip-joint pliers (installing a metal housing)

Installation in a cored fiberglass hull (page 17):

Hole saw for hull interior: 60mm *or* 2-3/8"

Fiberglass cloth and resin

or Cylinder, wax, tape, and casting epoxy

Device-net cable [maximum 2m (6')] (NMEA 2000)

Pencil

Cutting pliers

Phillips screwdriver

Wire strippers

Heat-shrink tubing

Heat gun

Blade screwdrivers

Wrench

CAUTION: Interference From Electronic Devices

Install the DX900+ sensor and the Processor a minimum of 1 m (3') from other electronic equipment and cables. The sensor may be susceptible to interference from strong electromagnetic fields caused by devices such as AC inverters, power supplies, or other on-board equipment. Interference may cause inaccurate speed readings.

Follow the precautions below for optimal product performance and to reduce the risk of property damage, personal injury, and/or death.

WARNING: Always wear safety glasses, a dust mask, and ear protection when installing.

WARNING: The **YELLOW** O-ring must be in place near the top of the insert to make a watertight seal.

WARNING: The O-rings must be intact and well lubricated to make a watertight seal.

WARNING: The valve is not a watertight seal! Be sure the insert or blanking plug is fully inserted into the housing, and the cap nut is screwed on completely.

WARNING: Always attach the safety wire to prevent the insert or blanking plug from backing out in the unlikely event that the cap nut fails or is screwed on incorrectly.

WARNING: Immediately check for leaks when the boat is placed in the water. Do not leave the boat unchecked for more than three hours. Even a small leak may allow considerable water to accumulate.

WARNING: Stainless steel housing in a metal hull—Be sure the washer contacts the hull. Do not tighten the hull nut with the washer against the isolation bushing, as the housing will not be firmly installed.

WARNING: The power supply must be OFF before making electrical connections.

WARNING: A safe installation requires a 0.5 amp fast-blow fuse or circuit breaker.

WARNING: The power supply voltage must be 9 - 16 VDC.

CAUTION: The sensor is NOT compatible with a bronze housing, because bronze may cause interference resulting in incorrect readings.

CAUTION: Never pull, carry, or hold the sensor by its cable; this may sever internal connections.

CAUTION: Plastic housing—Never use a fairing with a plastic housing; the protruding sensor would be vulnerable to damage from impact.

CAUTION: Metal housing—Never install a metal housing in a vessel with a positive ground system.

CAUTION: Stainless steel housing in a metal hull—Stainless steel housing must be isolated from a metal hull to prevent electrolytic corrosion. Use the isolation bushing supplied.

CAUTION: The sensor must be aligned within 1° of parallel to the centerline/keel of the boat.

CAUTION: The arrow on the top of the insert must point forward toward the bow area to align with the water flow.

CAUTION: The bottom of the insert must be flush with the bottom of the housing. Note that the electrodes will protrude into the water.

CAUTION: Do not paint the face of the insert with the electrodes.

CAUTION: The sensor must be in good contact with the water at all times.

CAUTION: Never use solvents. Cleaner, fuel, sealant, paint, and other products may contain solvents that can damage plastic parts, especially the insert's face.

IMPORTANT: Please read the Owner's Guide completely before proceeding. These instructions supersede any other instructions in your instrument manual if they differ.

Choosing the Mounting Location

CAUTION: Do not mount in line with or near water intake or discharge openings, or behind strakes, fittings, or hull irregularities that will disturb the water flow.

CAUTION: Never mount the sensor directly ahead of a depth transducer, since turbulence generated by the housing will adversely affect the depth transducer's performance, especially at high speeds. Mount side-by-side.

- The sensor must be continuously immersed in water.
- The water flowing under the hull must be smooth with a minimum of bubbles and turbulence (especially at high speeds).
- The transducer beam must be unobstructed by the keel or propeller shaft(s).
- Choose a location with a minimum deadrise angle, so the transducer beam will be aimed at the bottom.
- Choose an accessible spot inside the vessel with adequate space for the height of the housing, tightening the nuts, and installing the insert. Allow a minimum of 280mm (11").

Boat Types (Figure 2)

- **Fin keel sailboats**—Mount on or near the centerline and forward of the fin keel 300–600mm (1–2’).
 - **Full keel sailboats**—Locate amidships and away from the keel at the point of minimum deadrise.
 - **Displacement hull powerboats**—Locate amidships near the centerline. The starboard side of the hull where the propeller blades are moving downward is preferred.
 - **Planing hull powerboats**—Mount well aft, on or near the centerline, and *well inboard of the first set of lifting strakes* to insure that the sensor will be in contact with the water at high speeds. The starboard side of the hull where the propeller blades are moving downward is preferred.
- Outboard and I/O**—Mount just forward of the engine(s).
Inboard—Mount well ahead of the propeller(s) and shaft(s).
Stepped hull—Mount just ahead of the first step.
Boat capable of speeds above 25kn (29MPH)—Review the installation location and operating results of similar boats before proceeding.

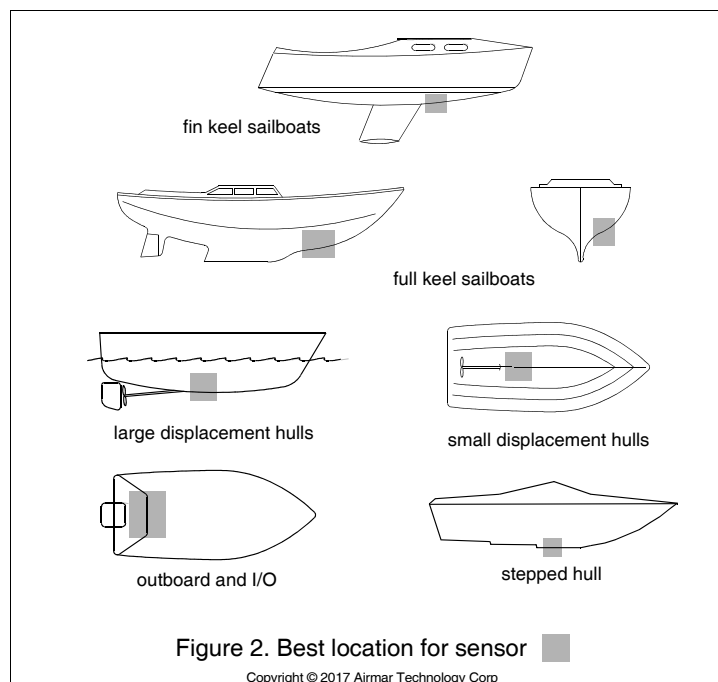

Anti-fouling Paint

CAUTION: Do not paint the face of the insert with the electrodes. This is different from the instructions given with many similar products. Paint will greatly reduce or prevent the electrodes from functioning.

Aquatic growth can accumulate rapidly on the sensor's surface reducing performance within weeks. Surfaces exposed to salt water must be coated with anti-fouling paint. *Use water-based anti-fouling paint only.* Never use ketone-based paint, since ketones can attack many plastics possibly damaging the sensor.

It is easier to apply anti-fouling paint before installation, but allow sufficient drying time. Reapply paint every 6 months or at the beginning of each boating season. Paint the following surfaces (Figure 3):

- Outside wall of the insert below the lower O-ring
- Bore of the housing up 30mm (1-1/4")
- Exterior flange of the housing
- Exposed end of the blanking plug

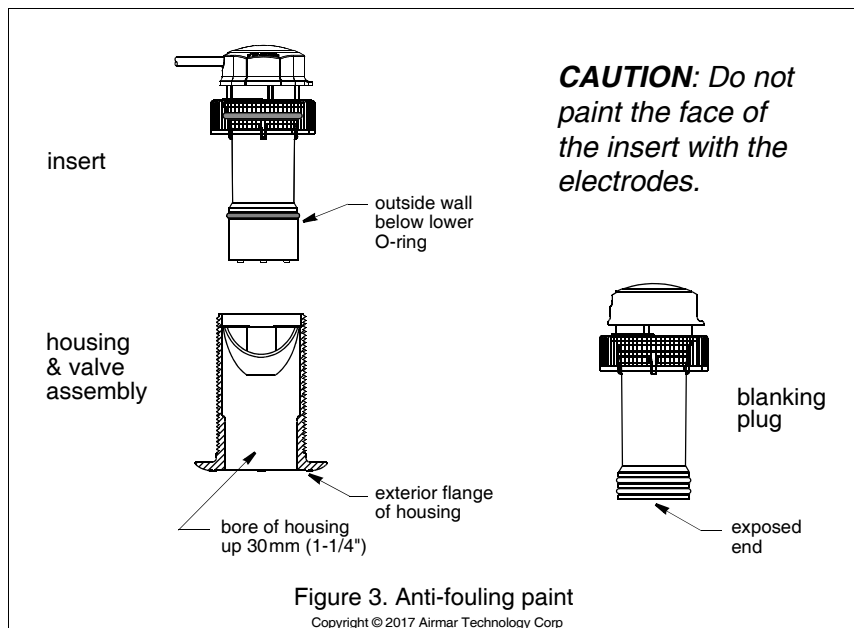

Installation

Hole Drilling

Cored fiberglass hull—Follow separate instructions on page 17

1. Drill a 3mm or 1/8" pilot hole from inside the hull. If there is a rib, strut or other hull irregularity near the selected mounting location, drill from the outside.
2. Using the appropriate size hole saw, cut a hole perpendicular to the hull from outside the hull.
3. Sand and clean the area around the hole, inside and outside, to ensure that the sealant will adhere properly to the hull. If there is any petroleum residue inside the hull, remove it with either mild household detergent or a weak solvent (alcohol) before sanding.

Metal hull—Remove all burrs with a file and sandpaper.

Bedding

CAUTION: Be sure the surfaces to be bedded are clean and dry.

Apply a 2mm (1/16") thick layer of marine sealant around the flange of the housing that contacts the hull and up the sidewall of the housing. *The sealant must extend 6mm (1/4") higher than the combined thickness of the hull, the washer, and the hull nut* (Figure 4). This will ensure there is sealant in the threads to seal the hull and to hold the hull nut securely in place.

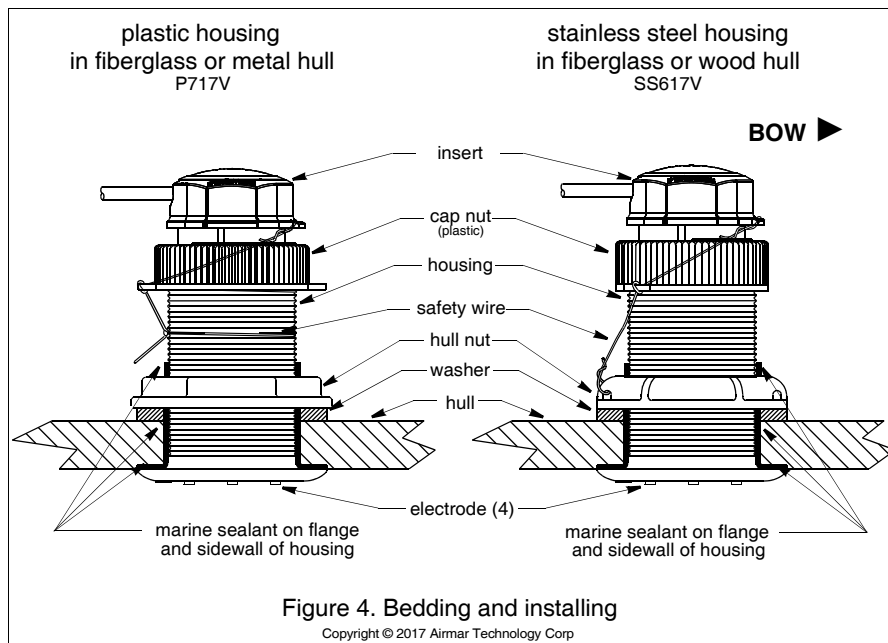

Stainless steel housing in a metal hull—A stainless steel housing must be isolated from a metal hull to prevent electrolytic corrosion. Slide the isolation bushing onto the housing (Figure 5). Apply *additional* sealant to the surfaces of the bushing that will contact the hull, filling any cavities in and around the bushing.

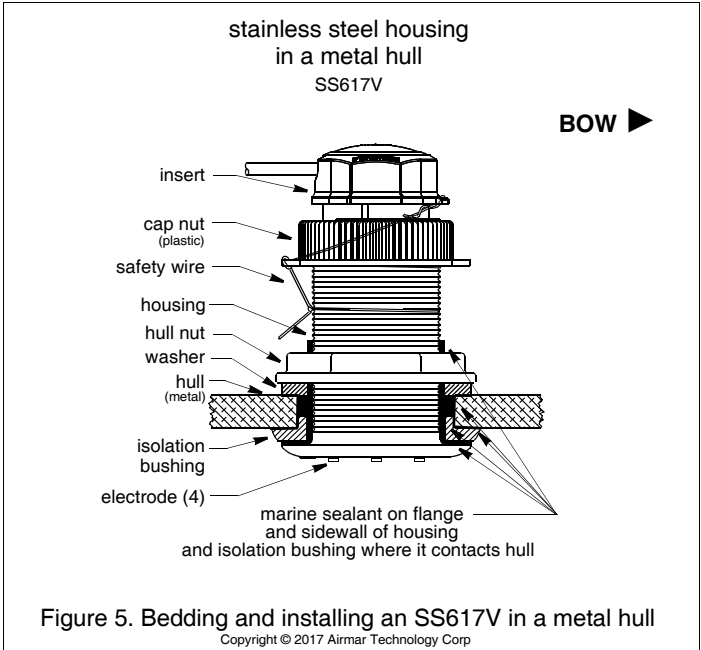

Installing

CAUTION: The arrow on the flange of the housing must point forward toward the bow area.

CAUTION: The bottom of the insert must be flush with the bottom of the housing for the sensor to work properly. Note that the four electrodes will protrude into the water.

1. The sensor must be aligned within 1° of parallel to the centerline/keel of the boat. At the center of the hole, snap a chalk line parallel to the keel/centerline (Figure 6).

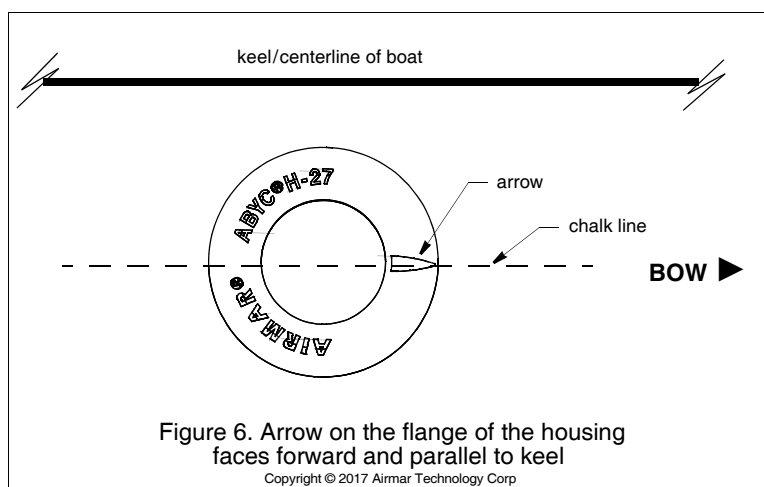

2. From outside the hull, push the housing into the mounting hole using a twisting motion to squeeze out excess sealant. *Align the arrow on the flange of the housing pointing forward toward the bow area.* Be sure the arrow is aligned PARALLEL to the centerline/keel of the boat.

- From inside the hull, check to be sure the notch in the housing is pointing forward toward the bow area (Figure 7). Slide the washer onto the housing (Figure 4).

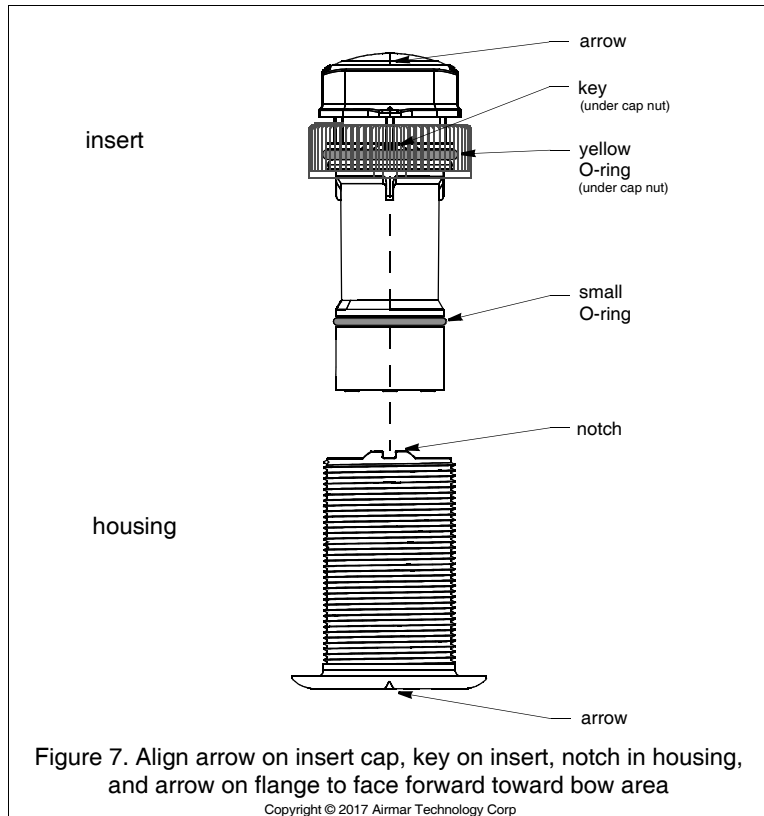

Stainless steel housing in a metal hull—Be sure the washer contacts the hull (Figure 5). *Do not tighten the hull nut with the washer against the isolation bushing, as the housing will not be firmly installed.* If necessary, sand the isolation bushing until the washer rests against the hull.

- Screw the hull nut in place.

Plastic housing—Do not clamp tightly on the wrench flats, fracturing the housing.

Plastic hull nut—**Hand tighten** only. Do not over tighten.

Metal hull nut—Tighten with slip-joint pliers.

Cored fiberglass hull—Do not over tighten, crushing the hull.

Wood hull—Allow the wood to swell before tightening the nut.

- Remove any excess marine sealant on the outside of the hull to ensure smooth water flow under the sensor.

6. The O-rings must be intact and well lubricated to make a watertight seal. After the marine sealant cures, inspect the O-rings, including the **YELLOW O-ring**, on the insert (replace if necessary) and lubricate them with the silicone lubricant supplied (Figure 7). Also lubricate the bore of the housing above the valve.
7. The insert must be fully inserted into the housing and the cap nut screwed on completely to make a watertight seal. Slide the insert into the housing with the *arrow on the top pointing forward toward the bow area* (Figure 8). Being sure the cable exit is pointing backward toward the stern, seat the insert into place with a *firm, pushing twisting motion* until the key fits into the notch. When this happens, you may hear a snap and the insert will no longer move. Be careful not to rotate the housing and disturb the sealant.

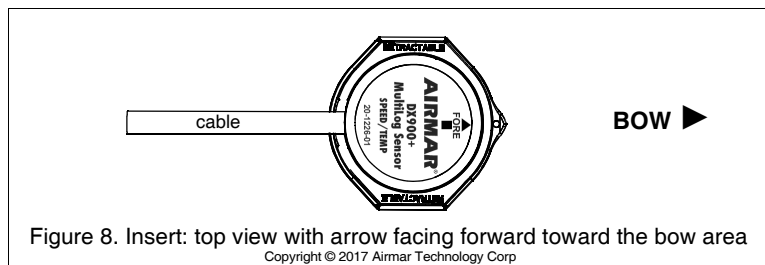

Screw the cap nut several turns until the threads are engaged. Being sure the cable exit is still pointing backward toward the stern, continue to tighten the cap nut completely. The arrow on the top of the insert, the key on the insert, the notch in the housing, and the arrow on the flange will be aligned facing forward toward the bow. **Hand tighten** only. Do not over tighten.

NOTE: *The electrodes will protrude into the water.*

8. Attach the safety wire to prevent the insert from backing out in the unlikely event that the cap nut fails or is screwed on incorrectly.

Plastic housing—Attach the safety wire to one eye in the hull nut (Figure 4). Keeping the wire taut throughout, lead the wire in a counterclockwise direction and thread it through one eye in the cap nut. Thread the wire through the eye a second time. Then lead the wire through the eye in the insert. Twist the wire securely to itself.

Metal housing—Wrap one end of the safety wire tightly around the housing and twist it together with the long end (Figure 4 or 5). Keeping the wire taut throughout, lead the wire straight up and through one eye in the cap nut. Thread the wire through the eye a second time. Then lead the wire counterclockwise and through the eye in the insert. Twist the wire securely to itself.

Installation in a Cored Fiberglass Hull

The core (wood or foam) must be cut and sealed carefully. The core must be protected from water seepage, and the hull must be reinforced to prevent it from crushing under the hull nut allowing the housing to become loose.

CAUTION: Completely seal the hull to prevent water seepage into the core.

1. Drill a 3mm or 1/8" pilot hole from inside the hull. If there is a rib, strut, or other hull irregularity near the selected mounting location, drill from the outside. (If the hole is drilled in the wrong location, drill a second hole in a better location. Apply masking tape to the outside of the hull over the incorrect hole and fill it with epoxy.)
2. Using a 51 mm or 2" hole saw, cut the hole from outside the hull through the *outer skin* only (Figure 9).
3. From inside the hull, use a 60mm or 2-3/8" hole saw to cut through the *inner skin* and most of the core. The core material can be very soft. Apply only light pressure to the hole saw after cutting through the inner skin to avoid accidentally cutting the *outer skin*.
4. Remove the plug of core material so the *inside* of the outer skin and the inner core of the hull are fully exposed. Sand and clean the inner skin, core, and the outer skin around the hole.
5. If you are skilled with fiberglass, saturate a layer of fiberglass cloth with a suitable resin and lay it inside the hole to seal and strengthen the core. Add layers until the hole is the correct diameter.
Alternatively, a hollow or solid cylinder of the correct diameter can be coated with wax and taped in place. Fill the gap between the cylinder and hull with casting epoxy. After the epoxy has set, remove the cylinder.
6. Sand and clean the area around the hole, inside and outside, to ensure that the marine sealant will adhere properly to the hull. If there is any petroleum residue inside the hull, remove it with either mild household detergent or a weak solvent (alcohol) before sanding.
7. Proceed with "Bedding" (page 12).

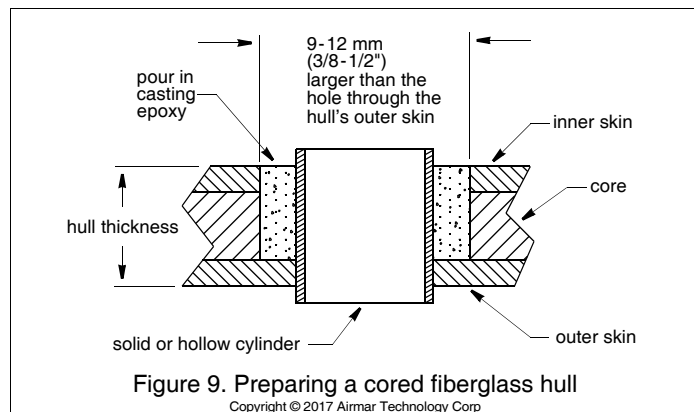

Cable Routing & Connecting

CAUTION: Do not remove the waterproof connector(s) to ease cable routing.

CAUTION: Be careful not to tear the cable jacket(s) when passing it through bulkheads and other parts of the boat. Use grommets to prevent chafing.

CAUTION: Coil any excess cable(s) and secure it with cable ties to prevent damage.

Speed & Temperature Only: NMEA 0183

Wire the sensor directly to the NMEA 0183 instrument. There is NO processor in this application.

1. If the power is connected to the instrument, disconnect it.
2. Route the sensor cable to the instrument. *Do not fasten the cable in place at this time.*
3. Being sure the power is OFF, connect the speed and temperature sensor cable to the instrument. Follow the instructions in your instrument owner's manual and refer to the wire colors and functions below:

Red	VDC+
Black	VDC-
White	A + NMEA bi-directional
Blue	B - NMEA bi-directional
Bare	Shield

Depth, Speed & Temperature: NMEA 2000 or NMEA 0183

To use the depth function, the sensor must be connected to the network or instrument through a processor. There are two versions of the processor: NMEA 2000 and NMEA 0183 compatible. Be sure you have the correct processor before beginning the installation.

Installing the Processor

1. Select a convenient, dry, mounting location for the water-resistant processor, a minimum of 1 m (3') from other cables and electronic equipment (Figure 10 or 11).
2. Route the DeviceNet/instrument cable from the processor location to the network backbone/instrument. *Do not fasten the cable in place at this time.*
3. Route the sensor cable to the processor location. *Do not fasten the cable in place at this time.*
4. Hold the processor at the selected location and mark the position of the four screw holes with a pencil.

NOTE: *If the processor will be mounted on a vertical surface, position the connectors downward to avoid water seeping into the box.*

5. At the marked locations, drill four 3mm or 1/8" holes approximately 10mm (3/8") deep. At the marked location, drill two 3mm or 1/8" holes approximately 10mm (3/8") deep.
6. Fasten the processor to the selected mounting surface at the previously-drilled holes, using the screws supplied.
7. **NMEA 2000**—Connect the DeviceNet cable to the network. Plug the DeviceNet cable into the port on the processor labeled NMEA 2000.

NMEA 0183—Wire the instrument cable to the instrument. Refer to the wire colors and functions below:

Red	VDC+	
Black	VDC-	
White	A +	NMEA bi-directional
Blue	B -	NMEA bi-directional
Bare	Shield	

Plug the instrument cable into the port on the processor labeled NMEA 0183.

8. Plug the sensor into the port on the processor labeled Sensor.
9. Fasten all the cables in place. Coil any excess cable(s) and secure it with cable ties to prevent damage.

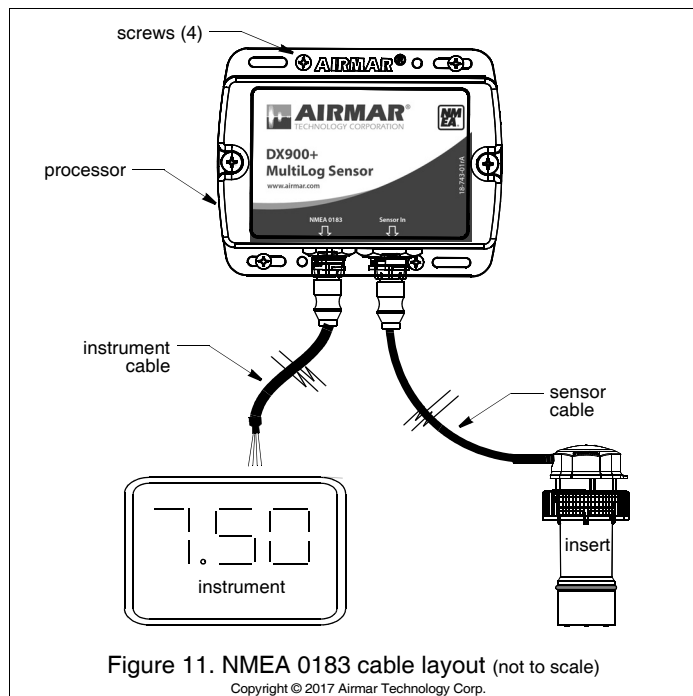
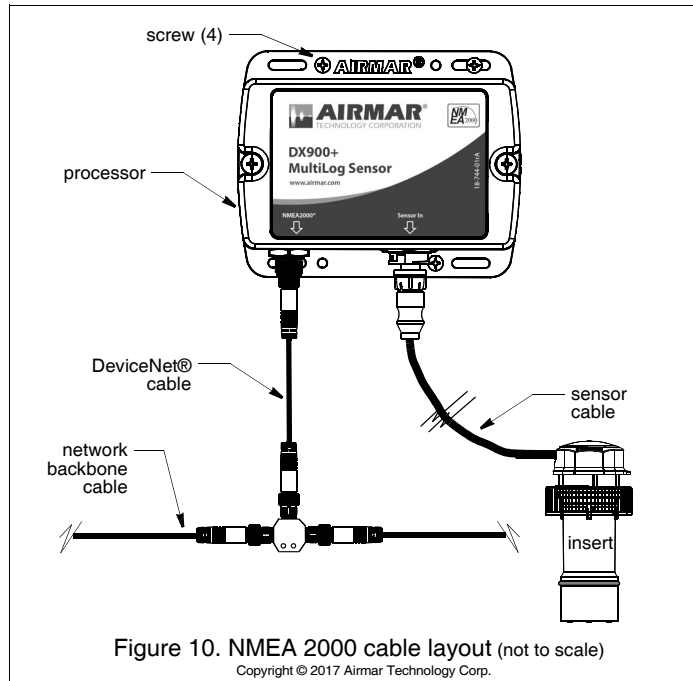

Checking for Leaks

When the boat is placed in the water, **immediately** check around the sensor for leaks. Note that very small leaks may not be readily observed. Do not leave the boat in the water for more than 3 hours before checking it again. If there is a small leak, there may be considerable bilge water accumulation after 24 hours. If a leak is observed, repeat “Bedding” and “Installing” **immediately** (pages 12 and 13).

Operation, Maintenance, & Replacement

How the Valve Works

THE VALVE IS NOT A WATERTIGHT SEAL! The sensor incorporates a self-closing valve which minimizes the flow of water into the boat when the insert is removed. The curved flap valve is activated by both a spring and water pressure. Water pushes the flap valve upward to block the opening, so there is no gush of water into the boat. Always install the insert or the blanking plug secured with the cap nut and safety wire for a watertight seal.

Using the Blanking Plug

To protect the insert, use the blanking plug:

- When the boat will be kept in salt water for more than a week.
 - When the boat will be removed from the water.
 - When aquatic growth buildup on the insert is suspected due to inaccurate readings from the instrument.
1. The O-rings must be intact and well lubricated to make a watertight seal. On the blanking plug, inspect the O-rings (replace if necessary) and lubricate them with the silicone lubricant supplied or petroleum jelly (Vaseline®) (Figure 12).
 2. Remove the insert from the housing by removing the safety wire and unscrewing the cap nut (Figure 4 or 5). This will jack up the insert. Remove the insert with a slow pulling motion. Replace it by sliding the blanking plug into the housing.
NOTE: *In the very unlikely event that the valve breaks, replace the housing the next time the boat is hauled.*
 3. With the blanking plug fully inserted, screw the cap nut several turns until the threads are engaged. Continue to tighten the cap nut completely. **Hand tighten** only. Do not over tighten.
NOTE: *The blanking plug must be fully inserted in the housing and the cap nut screwed on completely for a watertight seal.*
 4. Reattach the safety wire to prevent the blanking plug from backing out in the unlikely event that the cap nut fails or is screwed on incorrectly.

Winterizing

After the boat has been hauled for winter storage, remove the blanking plug to let the water drain away before reinserting it. This will prevent any water from freezing around the blanking plug and possibly cracking it.

Servicing the Insert

CAUTION: The electrodes on the insert's face are easily damaged. Do not scratch, gouge, or sand them with coarse sandpaper.

Cleaning the Electrodes

Aquatic growth can accumulate rapidly on the four electrodes reducing performance within weeks. Clean the electrodes with fine grit wet-dry sandpaper, being careful to avoid making scratches.

Replacing the O-rings

1. Install the yellow O-ring near the top of the insert (Figure 12). Install a small O-ring near the bottom.
2. Place the remaining two small O-rings near the bottom of the blanking plug.

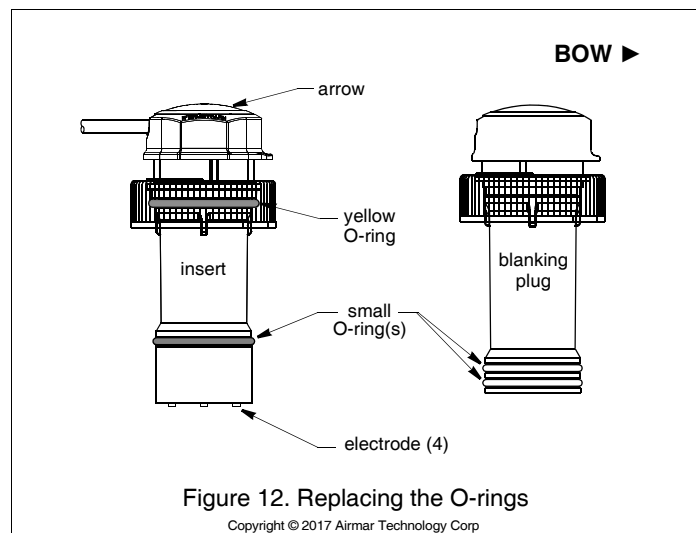

Replacement Sensor & Parts

The information needed to order a replacement Airmar sensor is printed on the cable tag. Do not remove this tag. When ordering, specify the part number and date. For convenient reference, record this information on the bottom of page one.

Lost, broken, or worn parts should be replaced immediately. If you have purchased a plastic housing and have a wood hull or desire greater strength, purchase an Airmar metal housing.

<u>Part</u>	<u>Airmar Part Number</u>
Blanking Plug	33-486-01
Hull Nut	04-004 (plastic)
	02-530-02 (stainless steel)
Isolation Bushing	04-186-1
O-ring Kit	20-519-01
Housing, Hull Nut & Washer	20-1256-01 (plastic P717V)
	33-617-01 (stainless steel SS617V)

Obtain parts from your instrument manufacturer or marine dealer.

Gemeco

USA

Tel: 803-693-0777

email: sales@gemeco.com

Airmar EMEA

Europe, Middle East, Africa

Tel: +33.(0)2.23.52.06.48

email: sales@airmar-emea.com

Troubleshooting

No Speed Reading

- Is the insert installed in the housing and connected to the instrument/Processor?
- Is the insert oriented with the arrow on the top pointing forward toward the bow area and the cable exiting toward the stern? If the insert cannot be seated in the housing with the arrow pointing forward, check that the arrow on the flange of the housing is pointing forward. If this is not the case, the housing needs to be reinstalled with the correct orientation.
- Is power being supplied to the instrument/processor? The power must be 9 to 16VDC. If there is no voltage, check the wiring.
- NMEA 0183 Speed & Temperature Only: Is the sensor wired to the instrument correctly?

Inaccurate Speed Readings

- If the speed sensor is ON when the boat is stationary, you may see a speed readout of a fraction of a knot because of water movement under the hull.
- If the speed reading is consistently the same percentage higher or lower than the true speed, it may be due to the speed function within the instrument. Refer to your instrument owner's manual.
- If speed readings are inaccurate above about 10 knots:
 - The sensor is installed in turbulent water. The cause may be water intake or discharge openings, strakes, fittings, hull irregularities upstream of the sensor, or the shape of the hull in that area. The sensor must be reinstalled in another location.
 - The insert is covered with aquatic growth. See "Servicing the Insert" on page 22.
 - Aerated water is flowing under the sensor because the boat is designed to pull air under the hull. The sensor will not work on this type of boat.



35 Meadowbrook Drive, Milford, New Hampshire 03055-4613, USA
www.airmar.com

